



P5T Series

Short Stroke Thruster



Parker
Global
Pneumatics



Contents

Features	F2	Dimensions.....	F14
Ordering Information	F3	Options	F16
Specifications	F4	Sensors	F21
Engineering Data.....	F6		

For installation, maintenance and replacement parts information, go to www.parker.com/actsafety.



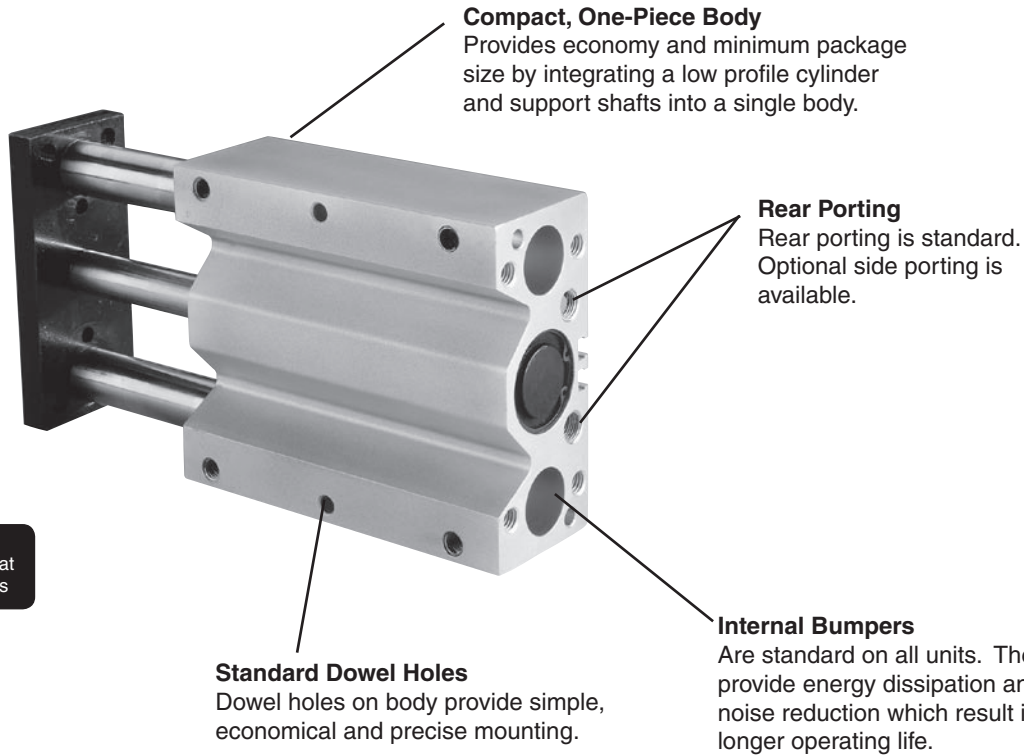

Compact, One-Piece Body
Provides economy and minimum package size by integrating a low profile cylinder and support shafts into a single body.

Rear Porting
Rear porting is standard. Optional side porting is available.

Internal Bumpers
Are standard on all units. These provide energy dissipation and noise reduction which result in longer operating life.

Standard Dowel Holes
Dowel holes on body provide simple, economical and precise mounting.

Top Porting
Top porting is standard. Optional side porting is available.

Sensor Grooves
Allow reed or solid state sensors to be mounted flush to the body. Magnetic piston is standard.

Dowel Holes
Standard dowel holes provide precision mounting and alignment on the tool plate.

Tooling Plate
Precision machined from steel, the tooling plate is thick and rigid to provide a durable connection.

Composite Bushings or Linear Ball Bearings
Parker uses a PTFE impregnated **composite bushing** which serves as a lubrication reservoir. This results in higher load carrying capabilities, both dynamic and static, with excellent resistance to shock loading. The impregnated lubricant also makes the bearings more dirt tolerant. **Composite bushings with oversized shafting** are available for high impact loads. Optional **recirculating ball bearings** provide precision operation with very low friction and wear.

3D CAD FILES
available for download at parker.com/pneumatics



Model Code and Ordering Information

Example: P5T-J032DHSN100

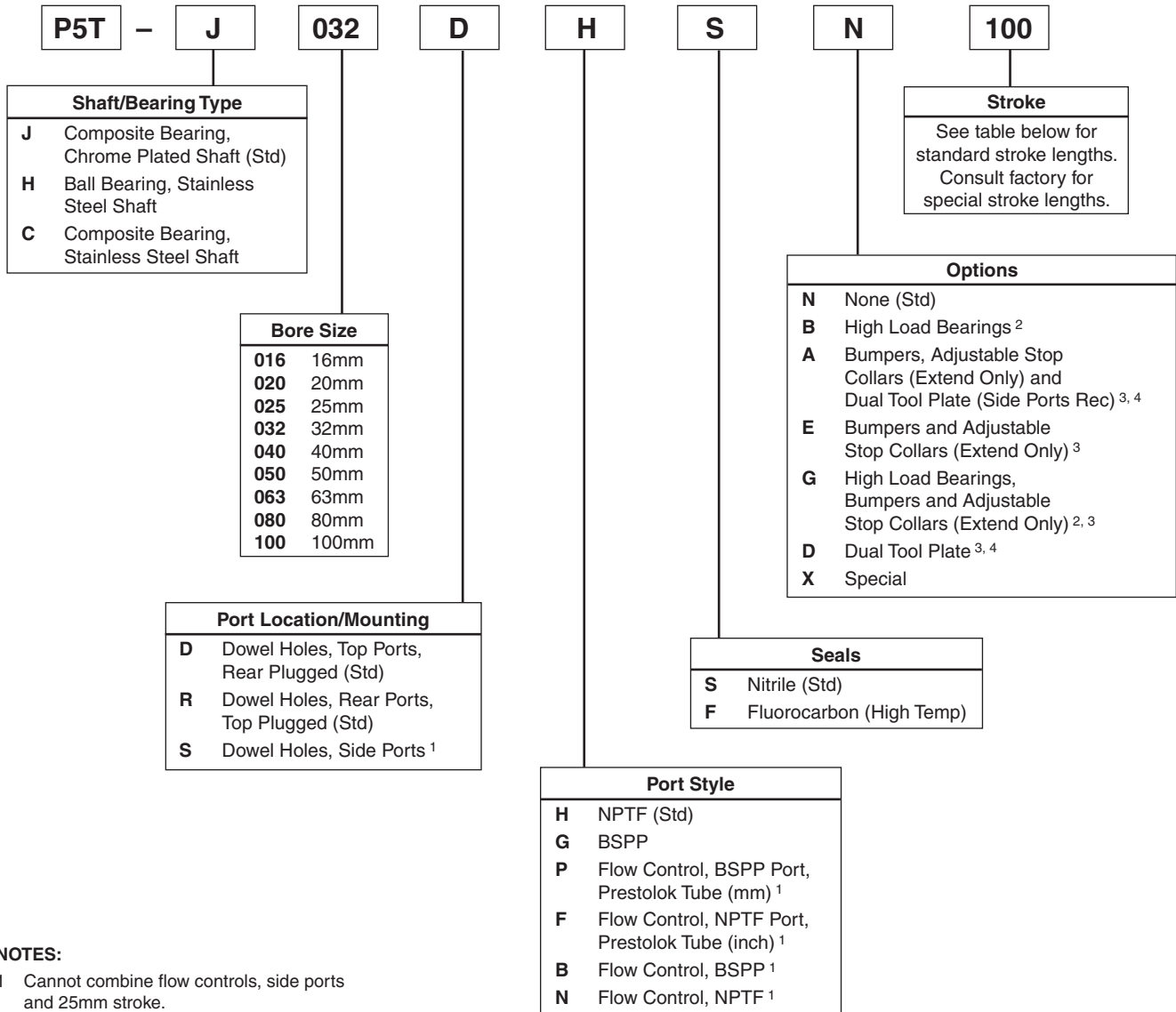

NOTES:

- Cannot combine flow controls, side ports and 25mm stroke.
- Not available with rear mounting and ports.
- Not available with rear port location (R).
- Includes high load bearings as standard.

Bore Size (mm)	Standard Strokes (mm)*									
	10	25	40	50	75	100	125	150	175	200
16	●	●	●	●	●	●				
20		●	●	●	●	●	●			
25		●		●	●	●	●	●		
32 - 100		●		●	●	●	●	●	●	●

*Consult factory for special stroke lengths.

Specifications

- Maximum operating pressure: 1MPa (10 bar/145 psi)
- Operating characteristics: Double acting
- Support rod sizes: Ø8 to 35mm
- Mounting: Unrestricted
- Operating temperature range (cylinder):
 - Nitrile seals (standard) -18° to 74°C (0° to 165°F)
 - Fluorocarbon seals* -18° to 121°C (0° to 250°F)
- Filtration requirement: 40 micron, filtered dry air

* See Fluorocarbon seal option for high temperature applications.

Construction

- BodyAluminum
- End Caps.....Aluminum
- Tool Plate..... Steel
- Piston Rod..... Stainless Steel
- Support Rods Steel (Chrome Plated)
- Rod Bolts..... Steel

Mounting Bolts

Bore Size	Socket Head Cap
16	M5 x .8
20	M5 x .8
25	M6 x 1.0
32	M8 x 1.25
40	M8 x 1.25
50	M10 x 1.5
63	M10 x 1.5
80	M12 x 1.75
100	M14 x 2.0

NOTE: When the P5T is used as an impact stopping system, mounting bolt thread engagement should be 1.5 times bolt diameter.

Quick Reference Data

Model (Bore Size)	Piston Rod (mm)	Bushings	Support Rods (mm)	Piston Bore Area Non-Rod Side		Max Stroke (mm)	Theoretical Force			
				mm ²	in ²		Extend @75 PSI (0.5 MPa)		Retract @75 PSI (0.5 MPa)	
							N	lb	N	lb
16	8	Ball	8	200	0.31	100	105	23.6	77.4	17.4
		Composite	10	200	0.31	100	105	23.6	77.4	17.4
20	10	Ball	10	316	0.49	125	164	36.8	123	27.8
		Composite	12	316	0.49	125	164	36.8	123	27.8
25	10	Ball	12	490	0.76	150	254	57	213.5	48
		Composite	16	490	0.76	150	254	57	213.5	48
32	16	Ball	16	804	1.25	200	402	93	302	70
		Composite	20	804	1.25	200	402	93	302	70
40	16	Ball	16	1257	1.95	200	628	146	528	123
		Composite	20	1257	1.95	200	628	146	528	123
50	20	Ball	20	1964	3.04	200	982	228	825	192
		Composite	25	1964	3.04	200	982	228	825	192
63	20	Ball	20	3117	4.83	200	1559	362	1492	326
		Composite	25	3117	4.83	200	1559	362	1492	326
80	25	Ball	25	5027	7.79	200	2513	584	2268	527
		Composite	30	5027	7.79	200	2513	584	2268	527
100	25	Ball	30	7854	12.17	200	3927	913	3574	856
		Composite	35	7854	12.17	200	3927	913	3574	856

Weights**P5T Series**

A074

Units with Composite Bushings

Weights in kg (lb)

Model	Standard Stroke (mm)									
	10	25	40	50	75	100	125	150	175	200
16	0.35 (0.77)	0.43 (0.95)	0.51 (1.13)	0.57 (1.25)	0.70 (1.54)	0.84 (1.84)	—	—	—	—
20	—	0.76 (1.66)	0.86 (1.90)	0.94 (2.06)	1.11 (2.45)	1.29 (2.85)	1.47 (3.24)	—	—	—
25	—	1.13 (2.48)	—	1.39 (3.05)	1.65 (3.63)	1.91 (4.20)	2.17 (4.77)	2.43 (5.35)	—	—
32	—	1.67 (3.68)	—	2.07 (4.55)	2.46 (5.42)	2.86 (6.29)	3.26 (7.17)	3.65 (8.04)	4.05 (8.91)	4.45 (9.78)
40	—	2.00 (4.40)	—	2.42 (5.32)	2.84 (6.25)	3.26 (7.17)	3.68 (8.10)	4.10 (9.02)	4.52 (9.94)	4.84 (10.65)
50	—	2.63 (5.78)	—	3.22 (7.08)	3.81 (8.38)	4.40 (9.69)	4.99 (10.99)	5.59 (12.29)	6.18 (13.59)	6.77 (14.89)
63	—	3.29 (7.24)	—	3.98 (8.75)	4.66 (10.25)	5.34 (11.75)	6.02 (13.25)	6.71 (14.76)	7.39 (16.26)	8.07 (17.76)
80	—	6.06 (13.33)	—	7.12 (15.66)	8.18 (18.00)	9.24 (20.33)	10.30 (22.66)	11.36 (24.99)	12.42 (27.33)	13.48 (29.66)
100	—	10.69 (23.52)	—	12.03 (26.47)	13.37 (29.42)	14.71 (32.37)	16.05 (35.32)	17.39 (38.27)	18.73 (41.22)	20.08 (44.17)

Units with Linear Ball Bushings

Weights in kg (lb)

Model	Standard Stroke (mm)									
	10	25	40	50	75	100	125	150	175	200
16	0.32 (0.70)	0.39 (0.86)	0.46 (1.02)	0.51 (1.13)	0.64 (1.40)	0.76 (1.67)	—	—	—	—
20	—	0.70 (1.53)	0.80 (1.75)	0.86 (1.90)	1.03 (2.26)	1.19 (2.62)	1.36 (2.99)	—	—	—
25	—	0.98 (2.15)	—	1.20 (2.64)	1.43 (3.14)	1.65 (3.64)	1.88 (4.14)	2.11 (4.63)	—	—
32	—	1.51 (3.31)	—	1.86 (4.09)	2.21 (4.86)	2.56 (5.63)	2.91 (6.41)	3.27 (7.18)	3.62 (7.96)	3.97 (8.73)
40	—	1.82 (4.01)	—	2.20 (4.83)	2.57 (5.66)	2.95 (6.49)	3.32 (7.31)	3.70 (8.14)	4.08 (8.97)	4.45 (9.79)
50	—	2.35 (5.17)	—	2.87 (6.32)	3.39 (7.47)	3.92 (8.62)	4.44 (9.76)	4.96 (10.91)	5.48 (12.06)	6.01 (13.21)
63	—	2.99 (6.58)	—	3.60 (7.93)	4.22 (9.28)	4.83 (10.63)	5.45 (11.98)	6.06 (13.33)	6.67 (14.68)	7.29 (16.03)
80	—	5.66 (12.45)	—	6.63 (14.59)	7.61 (16.74)	8.58 (18.88)	9.56 (21.03)	10.53 (23.18)	11.51 (25.32)	12.49 (27.47)
100	—	10.16 (22.36)	—	11.40 (25.09)	12.64 (27.82)	13.89 (30.55)	15.13 (33.28)	16.37 (36.01)	17.61 (38.74)	18.85 (41.46)

**Horizontal Load Capacity
Standard Unit**

P5T Series units will have the same load capacity regardless of orientation. The graphs below show maximum load capacity based on a unit life of 10 million cycles.

EXAMPLE: A P5T-16 with "stroke + d" of 75mm and composite bushings would have a load capacity of 50N.

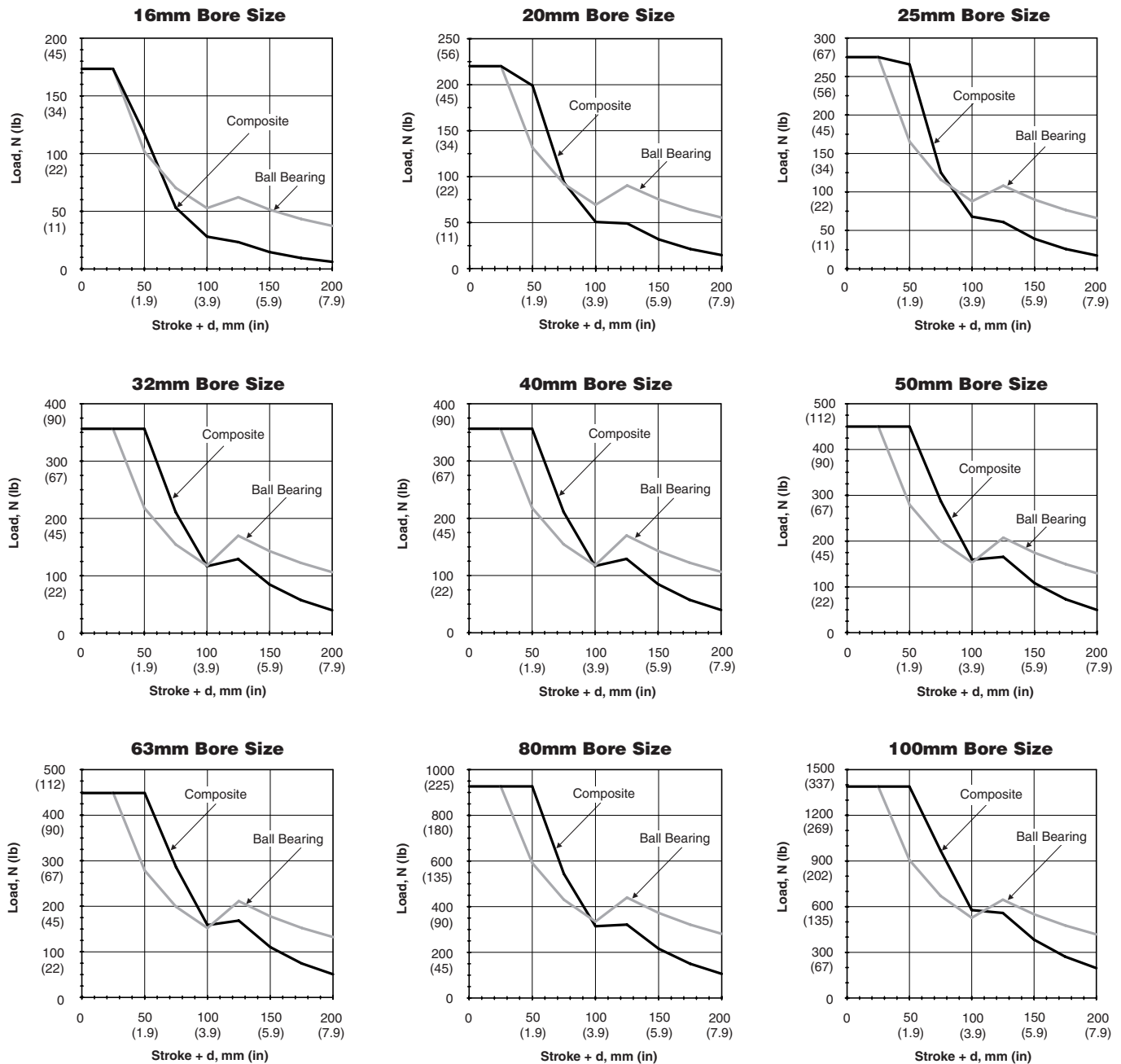
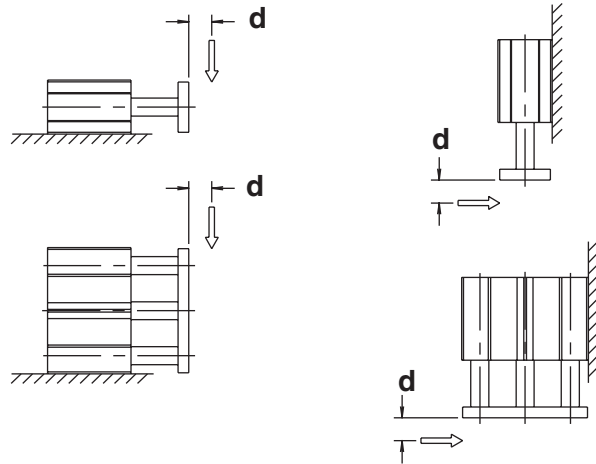

**Horizontal Load Capacity
with High Load Bearings and
Dual Tool Plate (D, A, B)**

P5T Series units will have the same load capacity regardless of orientation. The graphs below show maximum load capacity based on a unit life of 10 million cycles.

EXAMPLE: A P5T-20 with "stroke + d" of 100mm and high load composite bushings would have a load capacity of 125N.

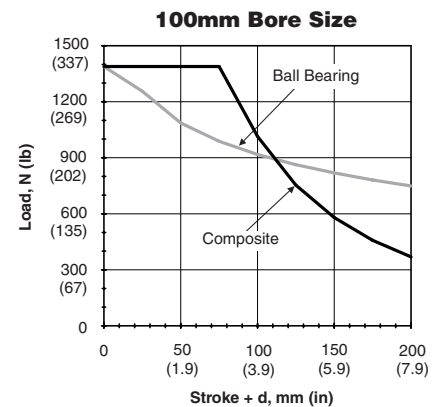
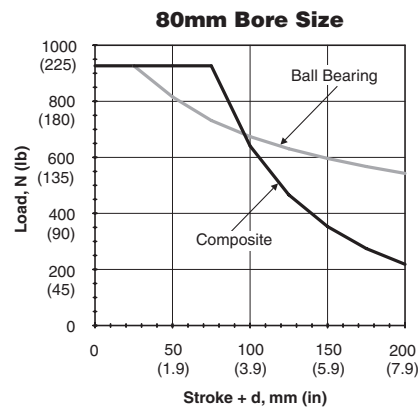
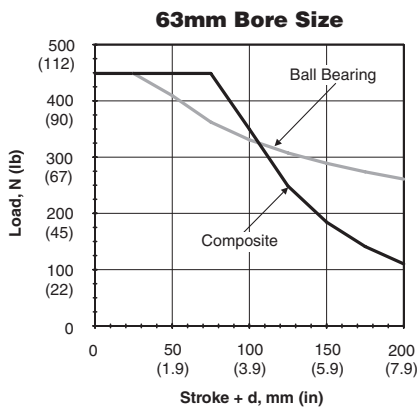
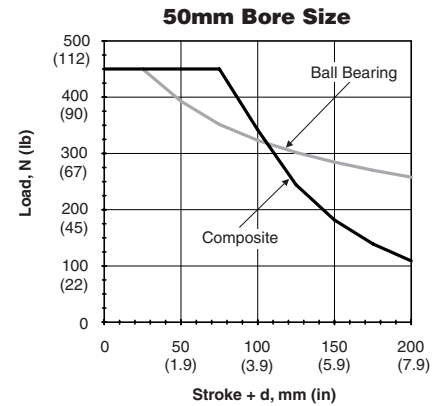
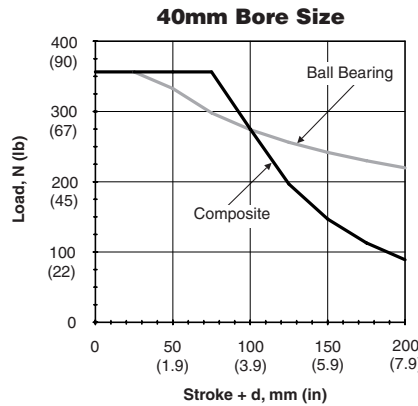
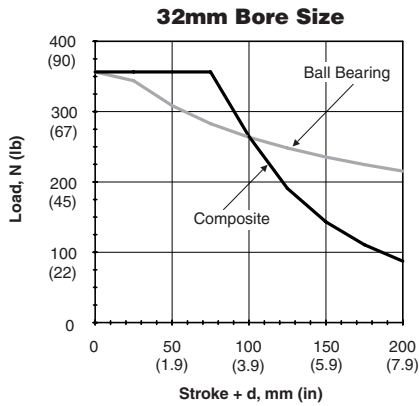
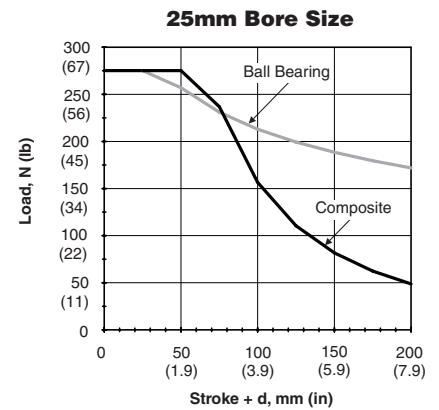
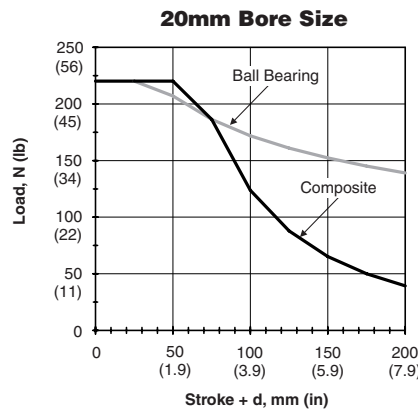
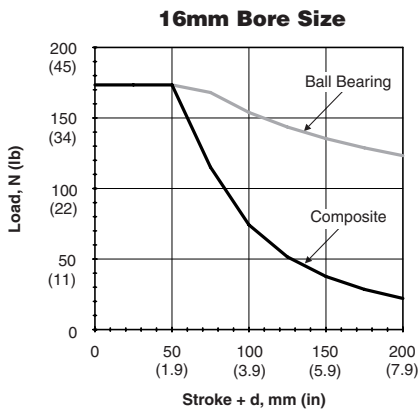
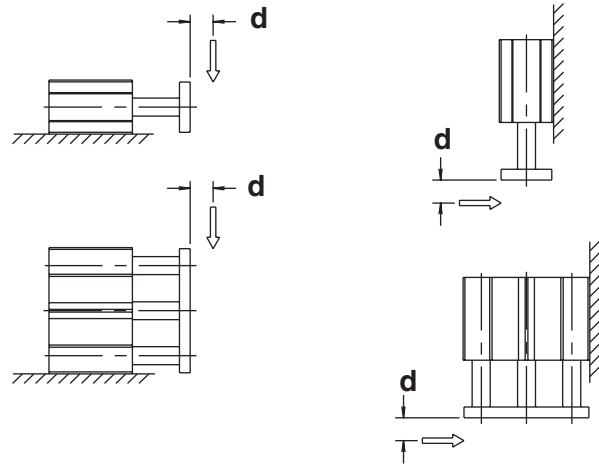

Load Stopping Capacity
Standard Unit

P5T Series actuators are ideal for conveyor stopping applications. Units can be mounted horizontally or vertically.

Composite bushings are strongly recommended for this type of application.

EXAMPLE: A P5T-50 unit with a stroke up to 50mm will stop an object moving at 40 cm/second (15.75 in/s) that weighs up to 50 kg (110 lb).

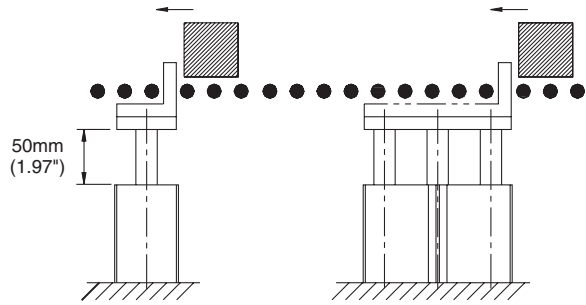

NOTE: The following graphs are based on 50mm of stroke.

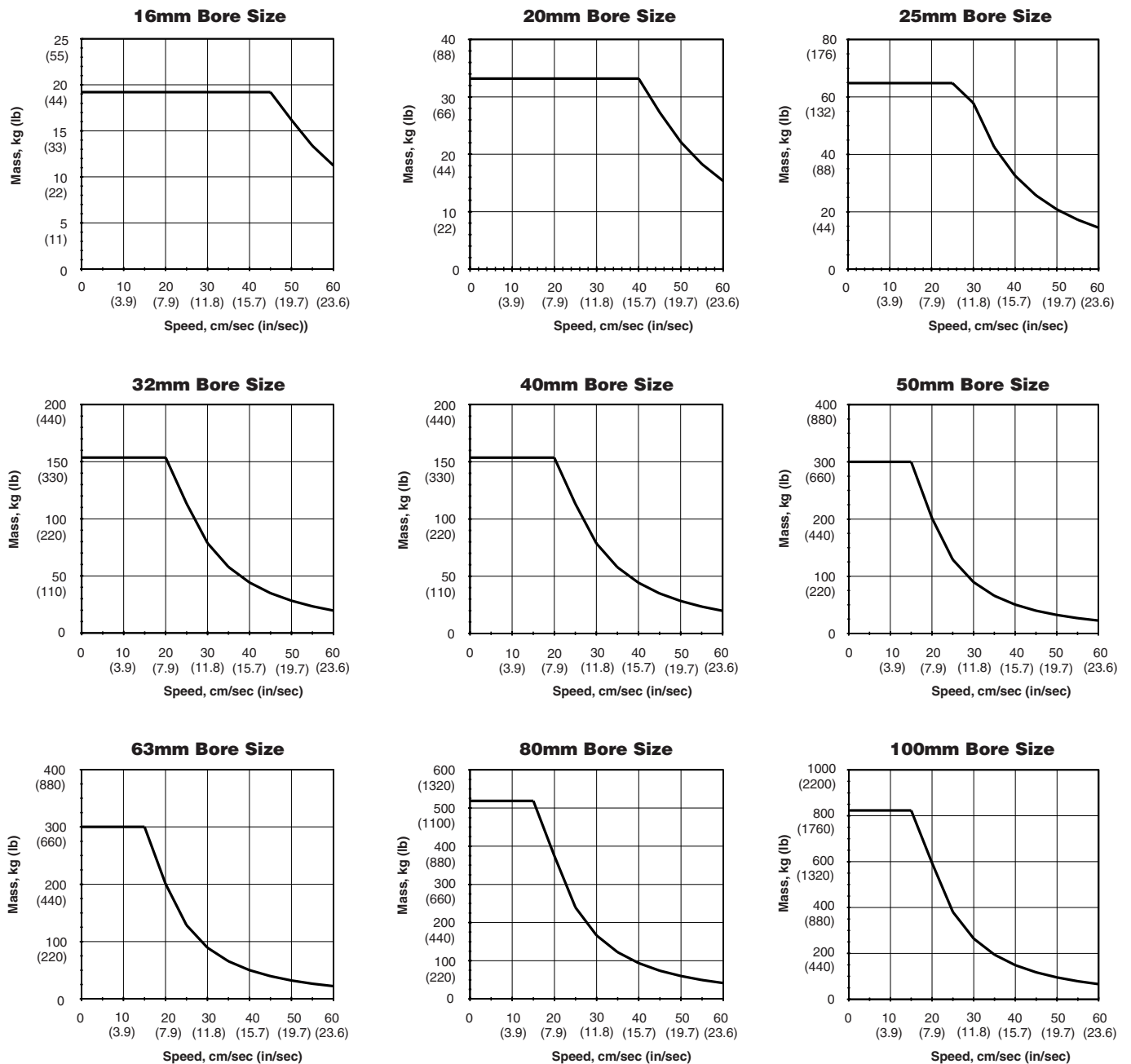

Load Stopping Capacity with High Load Bearings and Dual Tool Plate(D, A, B)

P5T Series actuators are ideal for conveyor stopping applications. Units can be mounted horizontally or vertically.

Composite bushings are strongly recommended for this type of application.

EXAMPLE: A P5T-25 unit with a stroke up to 50mm will stop an object moving at 40 cm/second (15.7 in/s) that weighs up to 46 kg (101 lb).

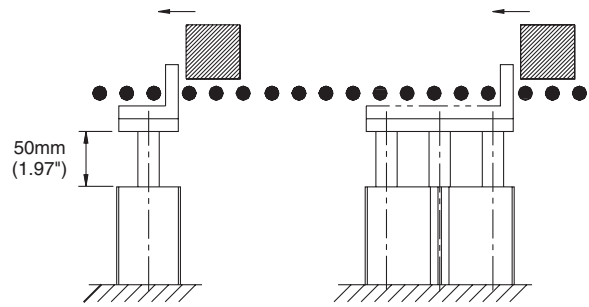

NOTE: The following graphs are based on 50mm of stroke.

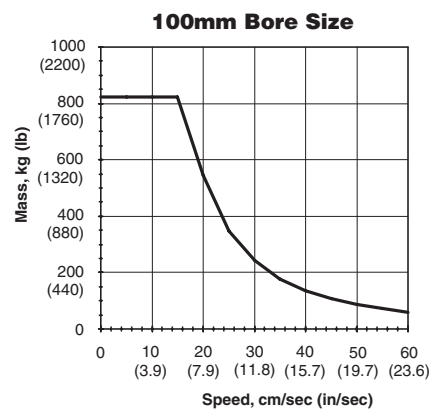
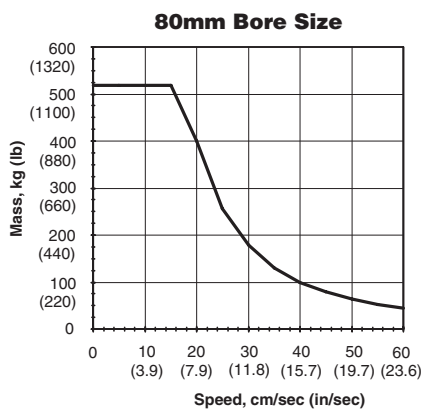
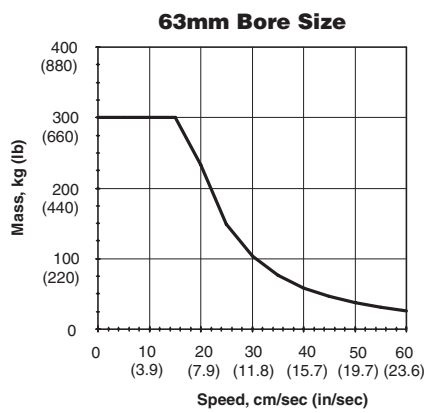
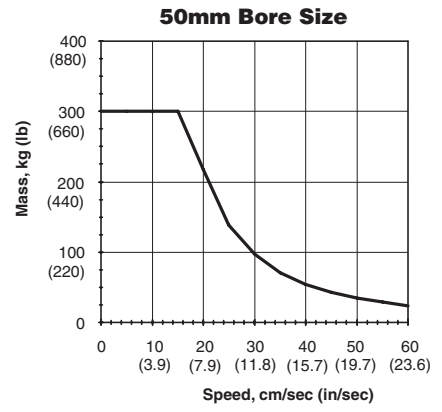
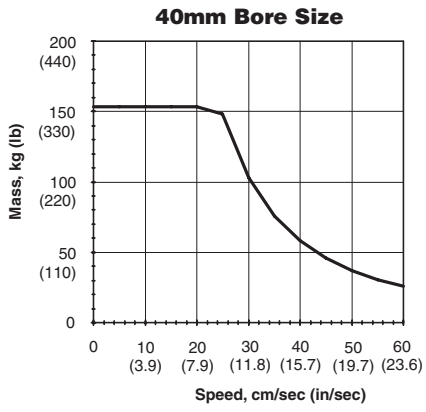
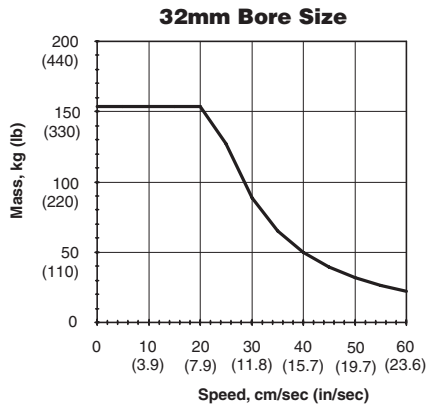
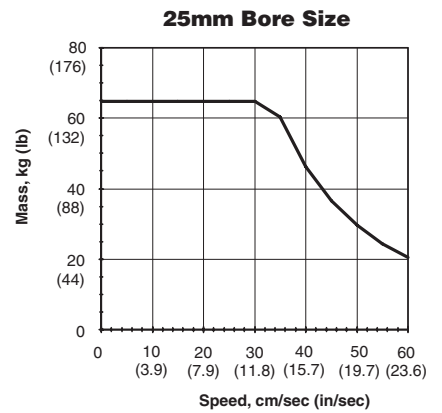
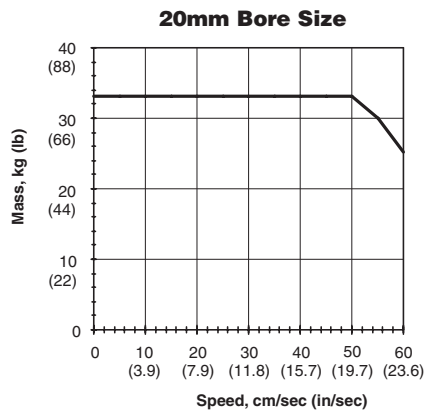
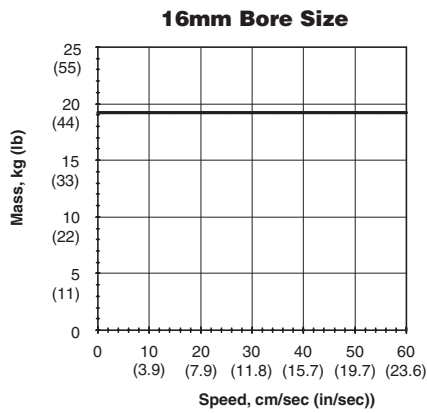

**Asymmetrical Torque Capacity
Standard Unit**

Asymmetrical loading occurs when the load is applied to one side of the unit. P5T Series units can resist torsional loads that are asymmetrical.

EXAMPLE: A mechanism exerts an asymmetrical load of 15Nm on a P5T-50 with 50mm "stroke+d". The P5T-50 with composite bushings will have adequate torsional capacity.

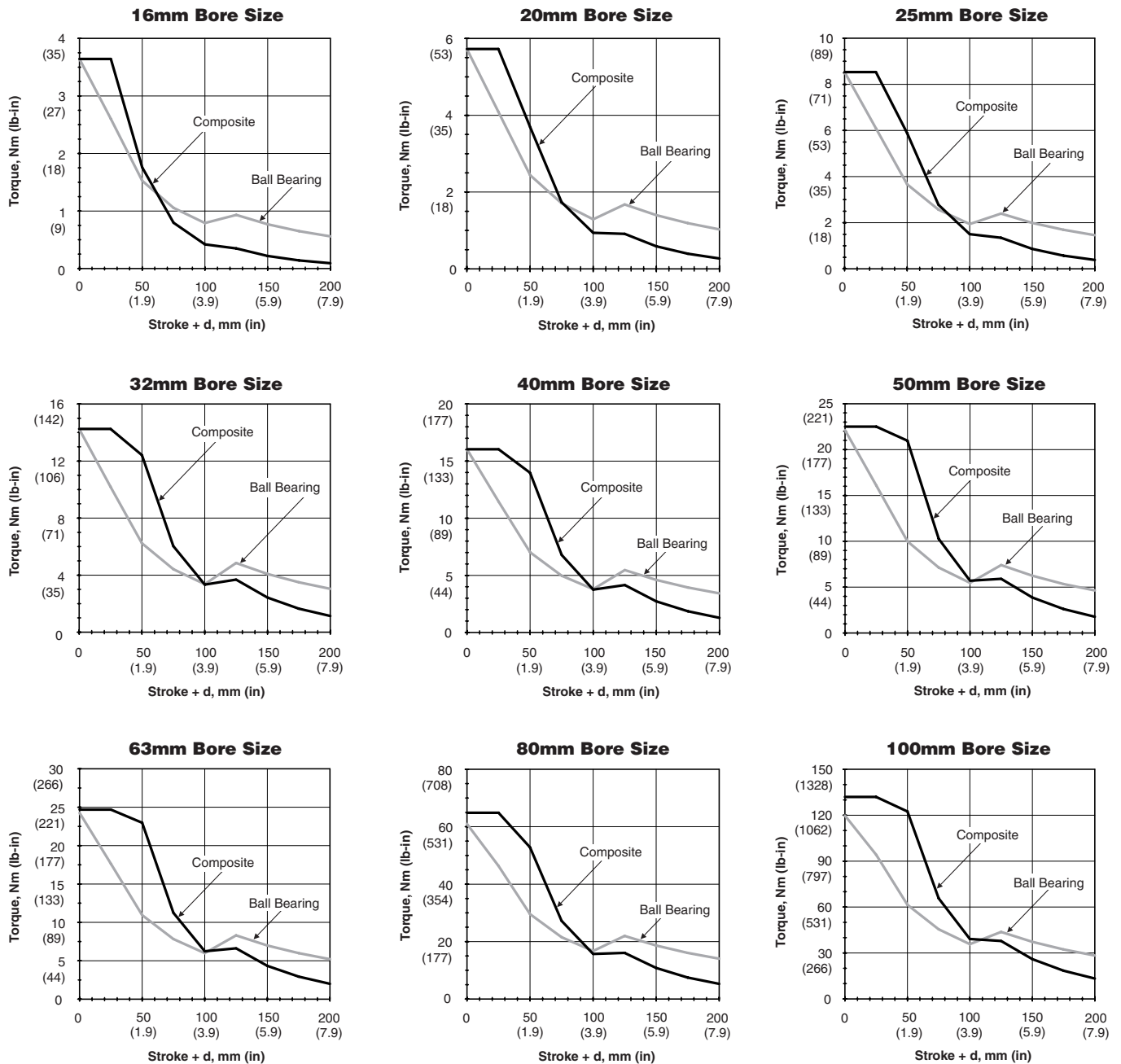
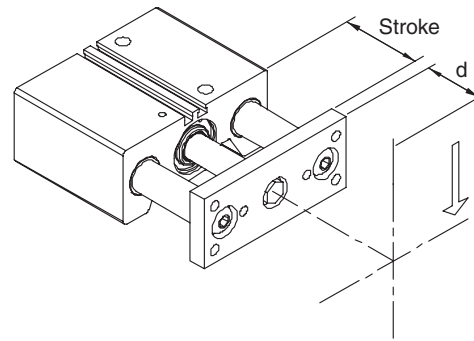

**Asymmetrical Torque Capacity
with High Load Bearings and
Dual Tool Plate (D, A, B)**

Asymmetrical loading occurs when the load is applied to one side of the unit. P5T Series units can resist torsional loads that are asymmetrical.

EXAMPLE: A mechanism exerts an asymmetrical load of 15Nm on a P5T-50 with 50mm "stroke+d". The P5T-50 with composite bushings will have adequate torsional capacity.

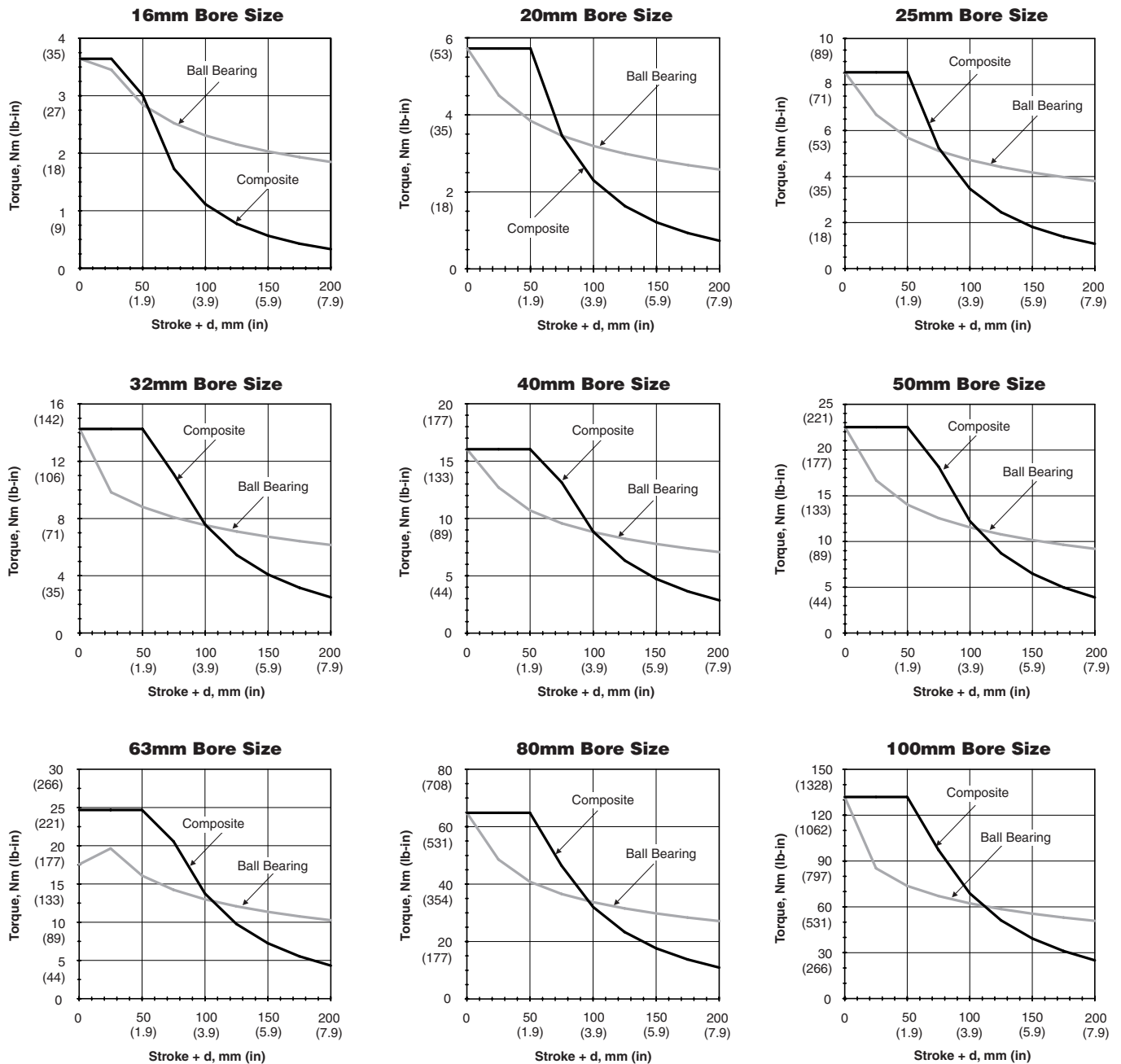
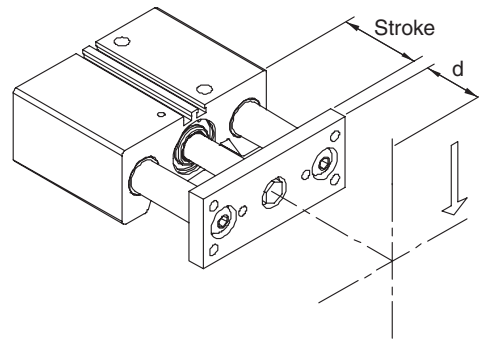

**Vertical Eccentric Load Capacity
Standard Unit**

P5T Series units mounted vertically will have the same eccentric load capacity regardless of orientation. The graphs provide maximum load capacity for an eccentric mounted load. The load is assumed to be mounted at the face of the tooling plate.

These load curves illustrate load ratings based on the bearing system of the product. Load rating is a key selection criterion but is not the only one to consider in the selection of a product.

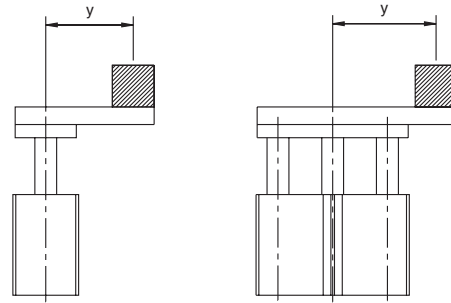

$y = \text{eccentricity distance}$

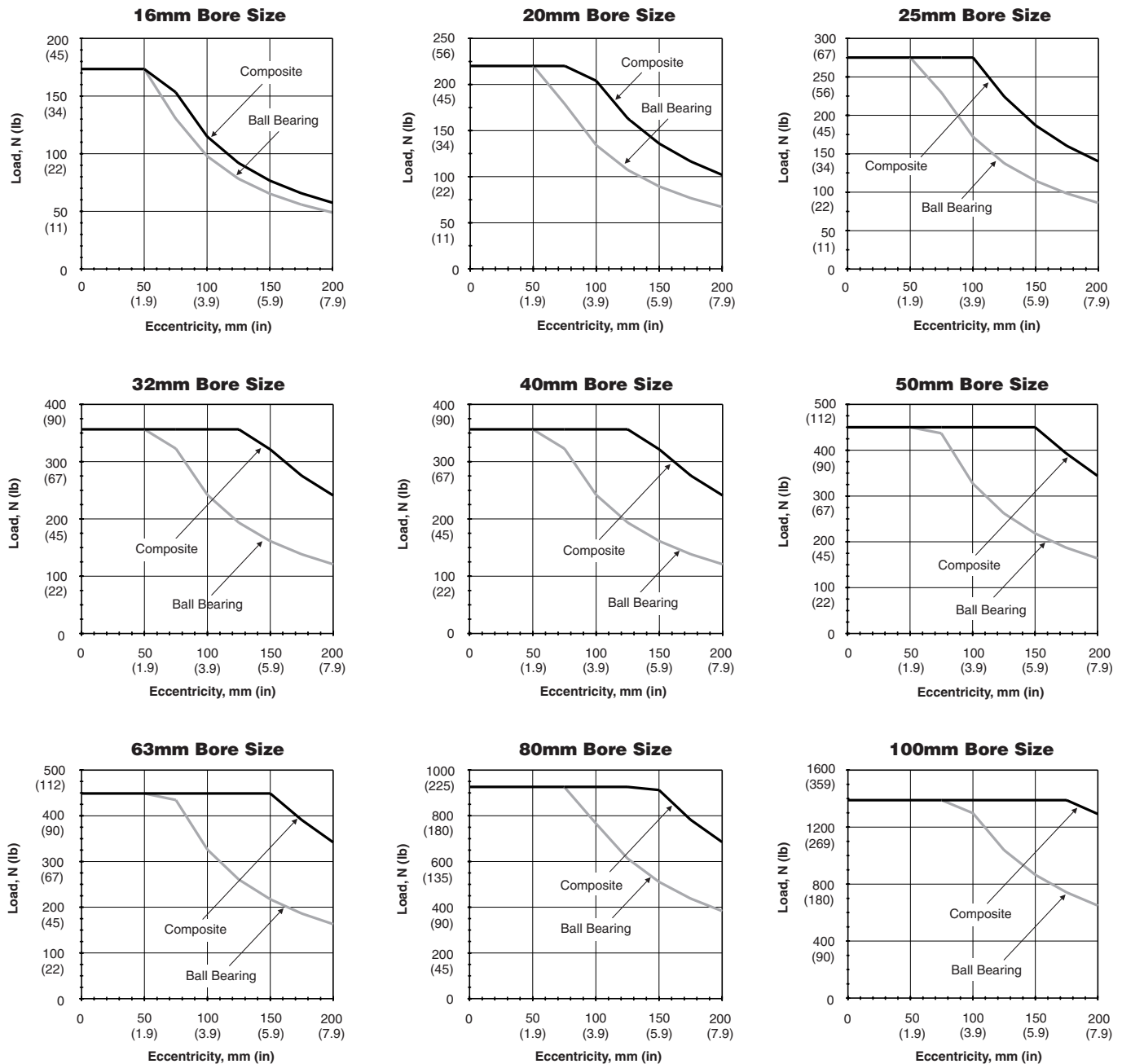

**Vertical Eccentric Load Capacity
with High Load Bearings and
Dual Tool Plate (D, A, B)**

P5T Series units mounted vertically will have the same eccentric load capacity regardless of orientation. The graphs provide maximum load capacity for an eccentric mounted load. The load is assumed to be mounted at the face of the tooling plate.

These load curves illustrate load ratings based on the bearing system of the product. Load rating is a key selection criterion but is not the only one to consider in the selection of a product.

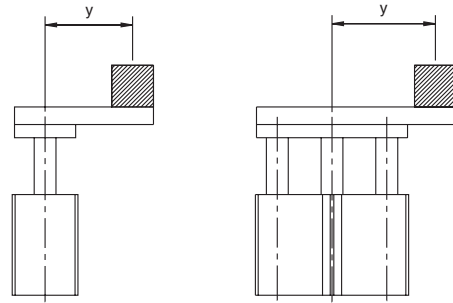

y = eccentricity distance

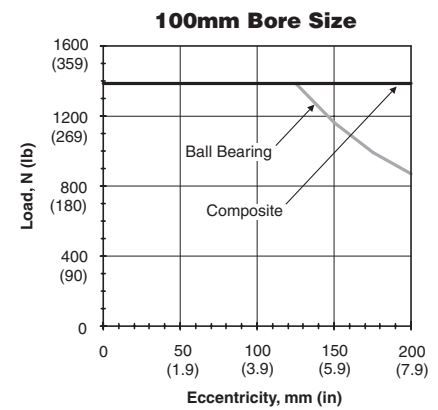
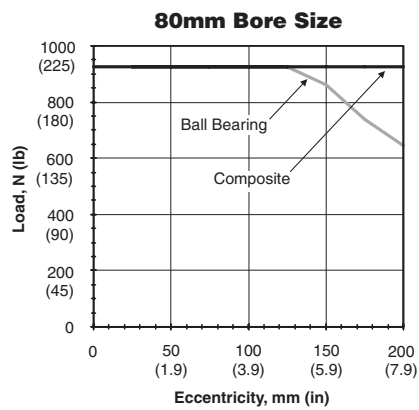
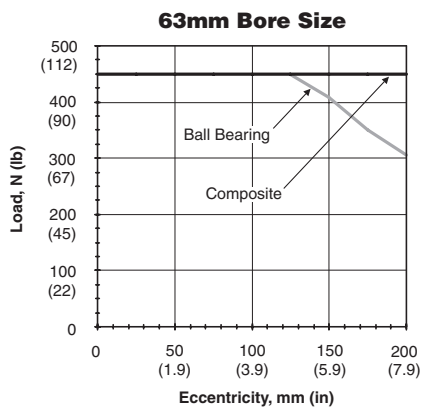
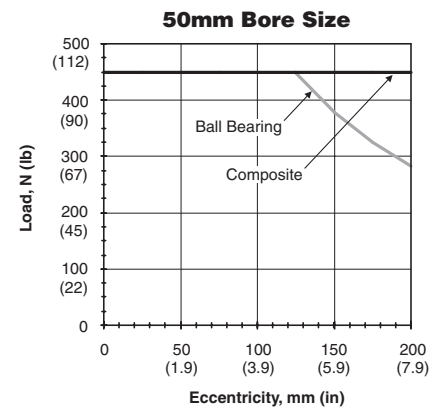
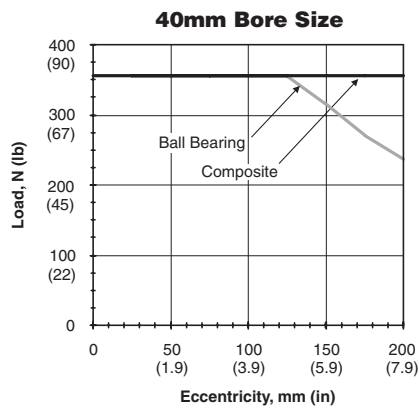
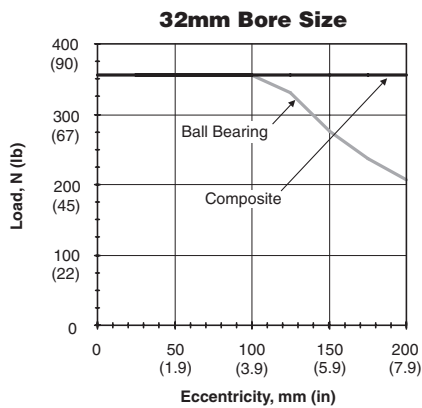
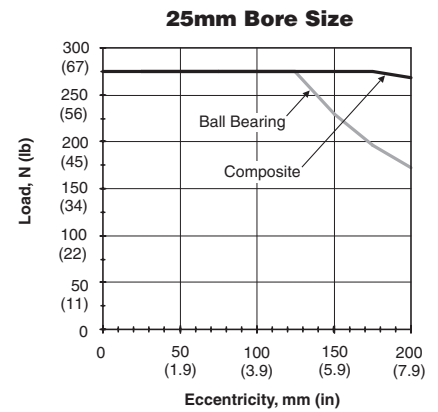
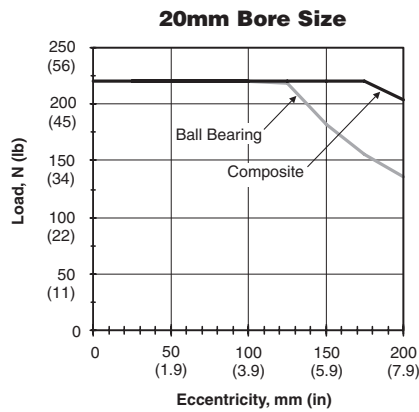
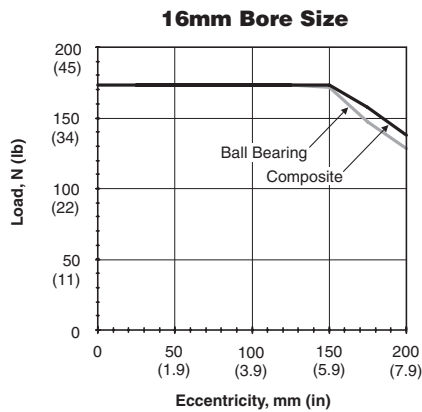

Basic Unit

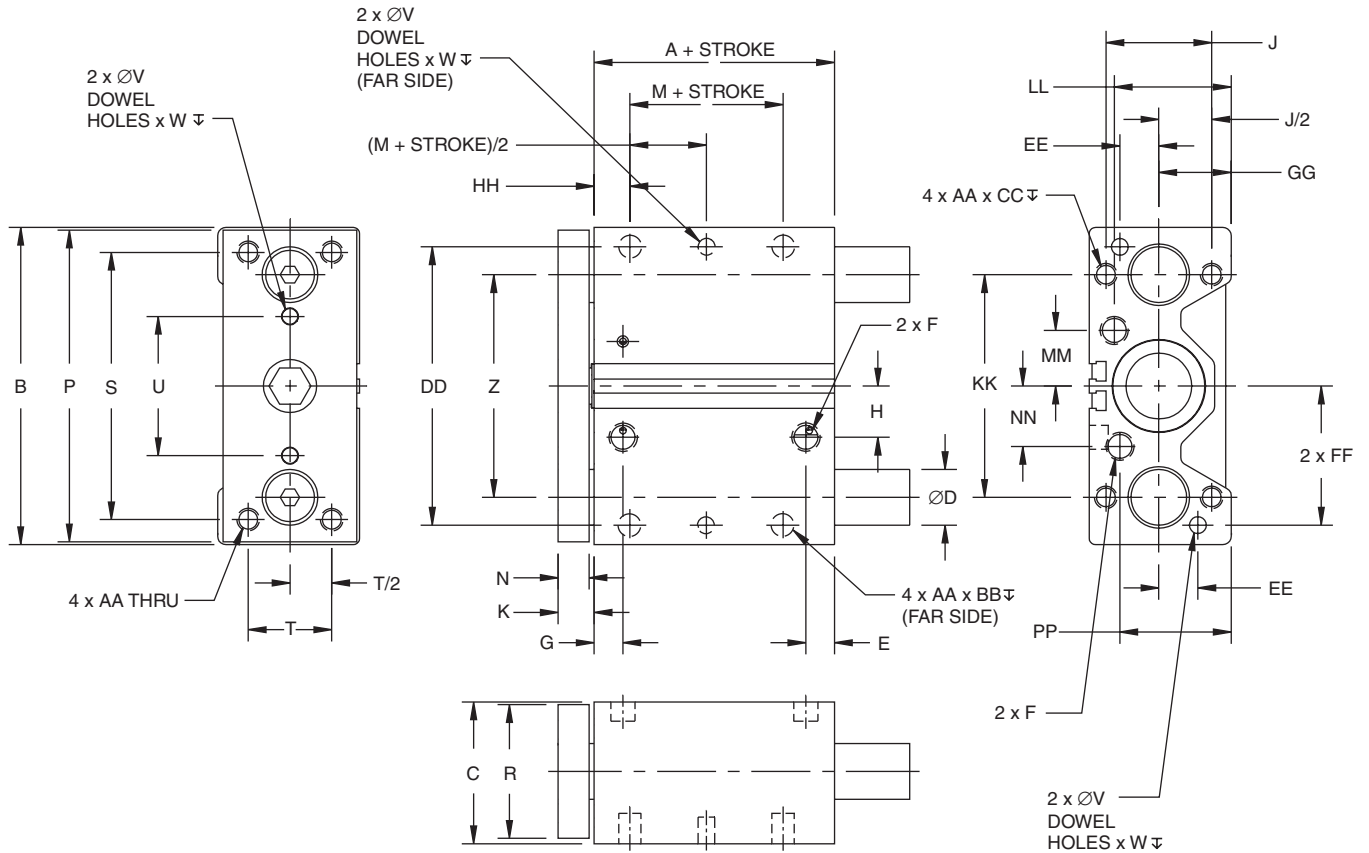

3D CAD FILES
 available for download at
parker.com/pneumatics

NOTE: On 16mm bore size only, one sensor groove is available. When utilizing two sensors on the 16mm bore size with 25mm stroke or less, use right angle short sensors.

Basic Unit

Model	A**	B	C	D ¹	D ²	E**	F		G	H	J	K
16	37.75 (1.49)	64 (2.52)	31 (1.22)	8 (0.315)	10 (0.394)	10.1 (0.40)	M5/10-32		10.1 (0.40)	6.95 (0.27)	22 (0.866)	9.94 (0.39)
20	36 (1.42)	74 (2.91)	36 (1.42)	10 (0.394)	12 (0.472)	19 (0.75)	1/8 NTPF OR BSPP		10 (0.39)	15.8 (0.62)	26 (1.024)	9.94 (0.39)
25	38 (1.50)	88 (3.46)	42 (1.65)	12 (0.472)	16 (0.630)	21 (0.83)	1/8 NPTF OR BSPP		11.4 (0.45)	15.5 (0.61)	32 (1.260)	9.94 (0.39)
32	36 (1.42)	114 (4.49)	51 (2.00)	16 (0.630)	20 (0.787)	10.26 (0.40)	1/8 NTPF OR BSPP		10.35 (0.41)	18.42 (0.73)	38 (1.496)	13.1 (0.52)
40	44 (1.73)	124 (4.88)	52 (2.05)	16 (0.630)	20 (0.787)	12.10 (0.48)	1/8 NPTF OR BSPP		14.9 (0.59)	22.53 (0.89)	38 (1.496)	13.1 (.052)
50	44.9 (1.77)	140 (5.51)	62 (2.44)	20 (0.787)	25 (0.984)	14.5 (0.57)	1/4 NTPF OR BSPP		16.1 (0.63)	27 (1.06)	44 (1.732)	14.7 (0.58)
63	50.05 (1.97)	150 (5.91)	75 (2.95)	20 (0.787)	25 (0.984)	16.4 (0.65)	1/4 NPTF OR BSPP		14.5 (0.57)	33 (1.30)	44 (1.732)	14.7 (0.58)
80	60.3 (2.37)	188 (7.40)	95 (3.74)	25 (0.984)	30 (1.181)	17.5 (0.610)	3/8 NTPF OR BSPP		19 (0.75)	37 (1.46)	56 (2.205)	18 (0.71)
100**	67.5 (2.60)	224 (8.82)	115 (4.53)	30 (1.181)	35 (1.38)	21.9 (0.862)	3/8 NPTF OR BSPP		23 (0.91)	40 (1.57)	62 (2.441)	18 (0.71)
Model	M	N	P	R	S	T	U	V	W	Z	AA	BB
16	7 (0.276)	7.94 (0.31)	62 (2.44)	25.4 (1.00)	52 (2.047)	16 (.630)	20 (0.787)	3 (0.118)	6 (0.236)	42 (1.654)	M5 X 0.8	7.5 (0.30)
20	10 (0.394)	7.94 (0.31)	72 (2.83)	31.8 (1.25)	60 (2.362)	18 (.709)	30 (1.181)	4 (0.157)	6 (0.236)	52 (2.047)	M5 X 0.8	7.5 (0.30)
25	10 (0.394)	7.94 (0.31)	86 (3.39)	38 (1.50)	70 (2.756)	26 (1.024)	34 (1.339)	4 (0.157)	6 (0.236)	62 (2.441)	M6 X 1.0	9 (0.35)
32	5 (0.197)	11.1 (0.44)	112 (4.41)	44.5 (1.75)	96 (3.780)	30 (1.181)	50 (1.969)	6 (0.236)	6 (0.236)	80 (3.150)	M8 X 1.25	11 (0.43)
40	10 (0.394)	11.1 (0.44)	122 (4.80)	44.5 (1.75)	106 (4.173)	30 (1.181)	60 (2.362)	6 (0.236)	6 (0.236)	90 (3.543)	M8 X 1.25	11 0.43)
50	10 (0.394)	12.7 (0.50)	138 (5.43)	57.2 (2.25)	120 (4.724)	40 (1.575)	60 (2.362)	8 (0.315)	8 (0.315)	100 (3.937)	M10 X 1.5	12 (0.47)
63	10 (0.394)	12.7 (0.50)	148 (5.83)	69.9 (2.75)	130 (5.118)	50 (1.969)	72 (2.835)	8 (0.315)	8 (0.315)	110 (4.331)	M10 X 1.5	15 (0.59)
80	15 (0.591)	16 (0.63)	185 (7.28)	89 (3.50)	160 (6.299)	60 (2.362)	92 (3.622)	10 (0.394)	10 (0.394)	140 (5.512)	M12 X 1.75	18 (0.71)
100	15 (0.591)	16 (0.63)	221 (8.70)	108 (4.25)	190 (7.480)	80 (3.150)	114 (4.488)	10 (0.394)	10 (0.394)	170 (6.693)	M14 X 2.0	21 (0.83)
Model	CC	DD	EE	FF	GG	HH	KK	LL	MM	NN	PP	Piston Rod
16	10 (0.39)	54 (2.126)	8 (0.315)	27 (1.063)	15 (0.591)	13.06 (0.514)	42 (1.654)	22.5 (0.88)	11.25 (0.44)	9.7 (0.38)	23.0 (0.91)	8 (0.315)
20	10 (0.39)	64 (2.520)	10 (0.394)	32 (1.260)	17 (0.669)	13.06 (0.514)	52 (2.126)	26.0 (1.02)	15.4 (0.61)	15.4 (0.61)	26.0 (1.0)	10 (0.394)
25	12 (0.47)	76 (2.992)	11 (0.433)	38 (1.496)	21 (0.827)	14.06 (0.553)	62 (2.441)	33.4 (1.31)	17 (0.67)	17 (0.67)	33.4 (1.31)	10 (0.394)
32	16 (0.63)	100 (3.937)	14 (0.551)	50 (1.969)	26 (1.024)	12.9 (0.508)	80 (3.150)	42 (1.65)	20 (0.79)	21.7 (0.85)	38 (1.50)	16 (0.630)
40	16 (0.63)	110 (4.33)	14 (0.551)	55 (2.165)	26 (1.024)	13.9 (0.547)	90 (3.543)	41 (1.61)	24 (0.95)	26.4 (1.04)	37.9 (1.49)	16 (0.630)
50	20 (0.79)	124 (4.882)	16 (0.630)	62 (2.441)	30 (1.181)	14.3 (0.563)	100 (3.937)	51 (2.01)	29 (1.14)	33 (1.30)	44 (1.73)	20 (0.787)
63	20 (0.79)	132 (5.197)	18 (0.709)	66 (2.598)	36.5 (1.437)	16.3 (0.642)	110 (4.331)	62 (2.44)	36 (1.42)	37.75 (1.49)	57.75 (2.27)	20 (0.787)
80	24 (0.94)	166 (6.535)	22 (0.866)	83 (3.268)	46.5 (1.831)	21 (0.83)	140 (5.512)	78 (3.07)	45 (1.77)	48 (1.89)	75.5 (2.97)	25 (0.984)
100	28 (1.10)	200 (7.874)	24 (0.945)	100 (3.937)	56.5 (2.224)	25 (0.98)	170 (6.693)	91.5 (3.60)	53 (2.09)	51 (2.01)	95.5 (3.76)	25 (0.984)

D¹ With linear ball bearing D² With composite bushing
 ** For Model 100 with 25mm stroke, A = 100.3 (3.95") and E = 28 (1.10")

All dimensions in mm (inch)



Options

Shaft Bearings

Composite bushings are supplied as standard.
Linear ball bearings are optional.

Selection should be based on the following criteria:

Application Requirement	Ball	Composite
Precision	Excellent	Good
Friction	Low	Higher
Friction coefficient	Constant	Variable
Precision over life of bearing	Constant	Variable
Static Load Capacity	Good	Excellent
Dynamic Load Capacity	Good	Good with lower efficiency
Vibration Resistance	Fair	Excellent
Contamination Resistance	Poor	Excellent
Washdown Compatibility	Poor	Excellent

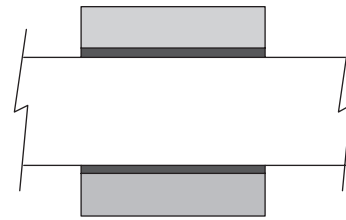

Composite Bushing (J,C)

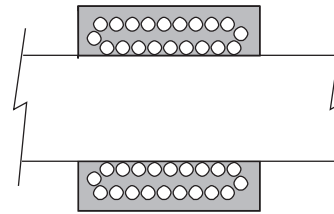

Recirculating Ball Bearing (H)

For bearing load capacities, reference the Engineering Data section.

Corrosion Resistant Shafting (C, H)

Chrome-plated case hardened, high carbon alloy steel shafting with composite bearings is utilized for standard steel slides. This may corrode in some applications. Stainless steel corrosion resistant shafting is available.

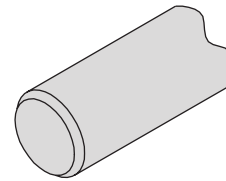

Side Porting (S)

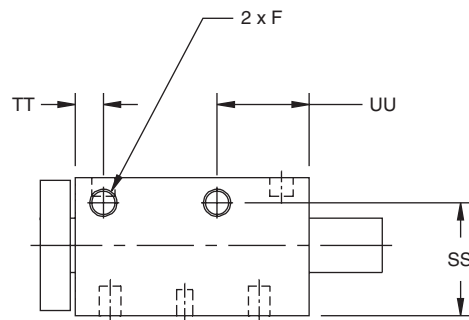

NOTES:

- 1 Side ports not available on 100mm bore units with 25mm of stroke.
- 2 Cannot use flow controls with 25mm stroke on any bore size.

Model	SS mm (in)	TT mm (in)	UU mm (in)	F
16	24.1 (.95)	10 (.39)	20 (.79)	10-32 or M5
20	29.00 (1.15)	10 (.39)	20 (.79)	10-32 or M5
25	35.15 (1.38)	11.4 (.45)	24 (.94)	10-32 or M5
32	43.2 (1.70)	10.35 (.41)	34 (1.34)	1/8 NTPF or BSPP
40	43.0 (1.69)	14.9 (.59)	34 (1.34)	1/8 NPTF or BSPP
50	51.25 (2.02)	16.1 (.64)	38 (1.50)	1/4 NTPF or BSPP
63	60.70 (2.39)	15.55 (.61)	41.8 (1.65)	1/4 NPTF or BSPP
80	75.5 (2.97)	19 (.75)	47 (1.85)	3/8 NTPF or BSPP
100	83.7 (3.30)	23 (.91)	53.3 (2.10)	3/8 NPTF or BSPP

Flow Controls (B, F, N, P)

Right angle flow control valves allow precise adjustment of cylinder speed by metering exhaust air flow. Prestolok push-in or threaded ports provide 360° orientation capability.

Model	A (in)	B (in)	C (in)	Imperial	
				Prestolok (F)	NPT (N)
16, 20*, 25*	0.87	0.96	0.39	5/32"	10-32
20, 25, 32, 40	1.63	1.38	0.67	5/32"	1/8
50, 63	1.86	1.64	0.91	1/4"	1/4
80, 100	2.15	1.90	1.06	3/8"	3/8
Model	A (mm)	B (mm)	C (mm)	Metric	
				Prestolok (P)	BSPP (B)
16, 20*, 25*	22.0	24.5	10.0	4mm	M5
20, 25, 32, 40	34.5	31.6	14.4	6mm	1/8
50	41.0	34.9	18.4	6mm	1/4
63	41.0	41.3	18.4	10mm	1/4
80	51.0	46.7	21.6	10mm	3/8
100	51.0	46.7	21.6	12mm	3/8

* Side ports only.

NOTE:

When flow controls are specified with rear ports, a 90° right angle fitting is supplied to provide ample rod clearance in the rear.

Prestolok flow controls are not available on 32-100mm bore sizes with 25mm of stroke.

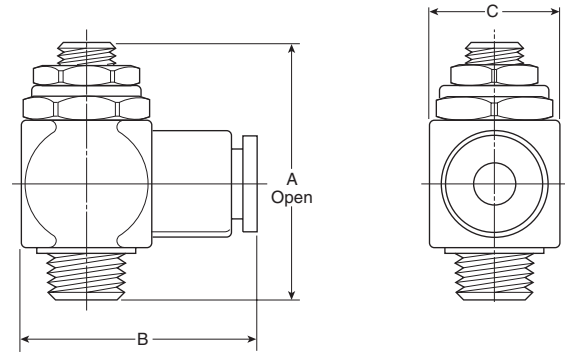
**Fluorocarbon Seals (F)**

Standard abrasion resistant nitrile seals should be used for general purpose applications with temperatures of -18 to 74°C (0 to 165°F). Fluorocarbon seals are recommended for high temperature applications up to 121°C (250°F).

Feature	Temperature Range
Bumpers	-18 to 93°C (0 to 200°F)
Magnets	-18 to 74°C (0 to 165°F)
Sensors	-10 to 85°C (14 to 185°F)

Standard Length – No Options (N),

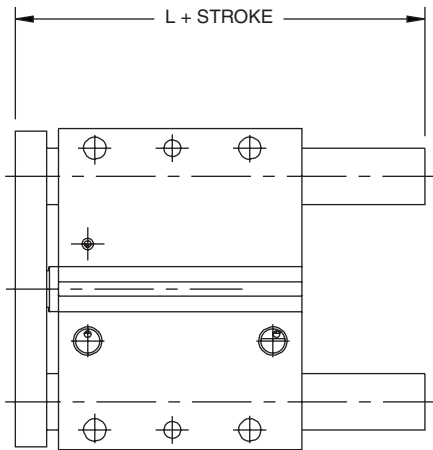

Model	Stroke (mm)	L	
		mm	inch
16	10*, 25, 40, 50, 75	60.2	2.37
	100	75.2	2.96
20	25, 40, 50, 75	66.9	2.63
	100, 125	91.9	3.62
25	25, 50, 75	69.9	2.75
	100, 125, 150	91.9	3.62
32	25, 50, 75, 100	77.9	3.07
	125, 150, 175, 200	116.0	4.57
40	25, 50, 75, 100	77.9	3.07
	125, 150, 175, 200	116.0	4.57
50	25, 50, 75, 100	84.0	3.31
	125, 150, 175, 200	124.1	4.89
63	25, 50, 75, 100	84.0	3.31
	125, 150, 175, 200	124.1	4.89
80	25, 50, 75, 100	101.8	4.00
	125, 150, 175, 200	140.0	5.51
100	25**, 50, 75, 100	120.3	4.74
	125, 150, 175, 200	158.4	6.24

* For Model 16 with 10mm stroke, L = 37.7 mm (1.48").

** For Model 100 with 25mm stroke, L = 122.8mm (4.8").

High Load Bearings (B)

The standard bearing configuration locates both sets of bearings at the tooling plate end of the actuator providing a compact actuator package. The high load bearings option (B) locates the bearings at the extreme ends of the housing, increasing the dynamic and static load capacity. The bearing centerlines increase as stroke length increases.

NOTE: Rear mounting and ports are not available with the high load bearing option.

Standard Bearings

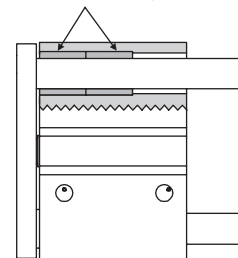

High Load Bearings

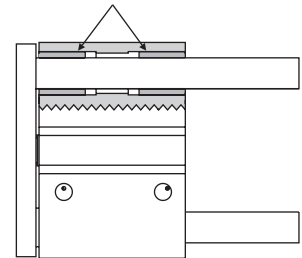

Dimensions

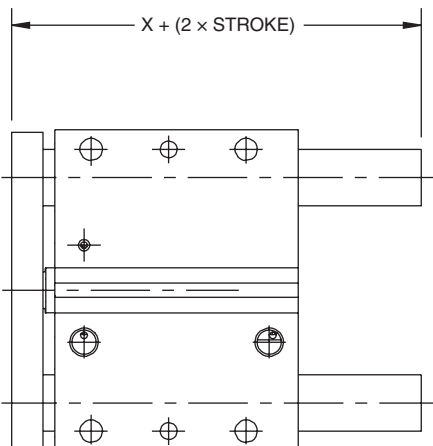

Model	X	
	mm	inch
16	49.7	1.955
20	47.0	1.849
25	49.9	1.963
32	51.1	2.012
40	59.1	2.327
50	61.6	2.425
63	66.8	2.630
80	79.6	3.135
100	86.1	3.391

Dual Tool Plate (D)

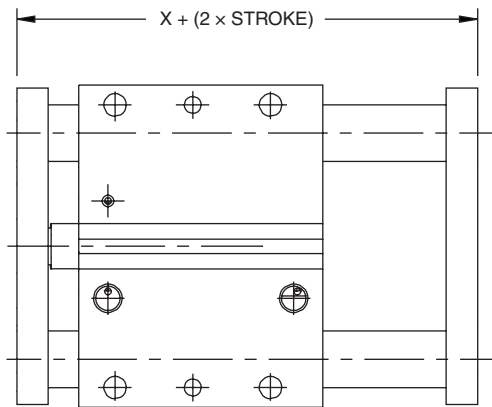

Notes:

1. Load capacities increase on dual tool plate (D & A). For load capacities, use the high load bearing graphs.
2. Rear mounting holes and rear ports are not available with Options D, A, and E.

Bumpers, Stop Collars & Dual Tool Plate (A)

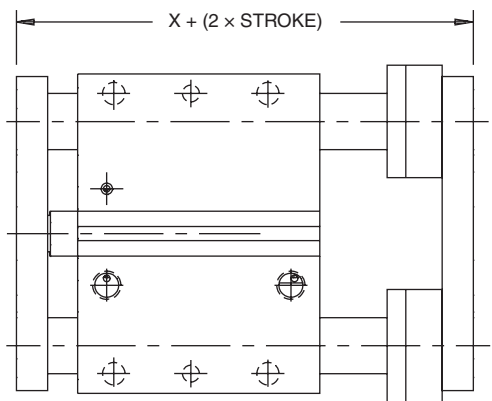

Bumpers & Adjustable Stop Collars, Extend Only (E)

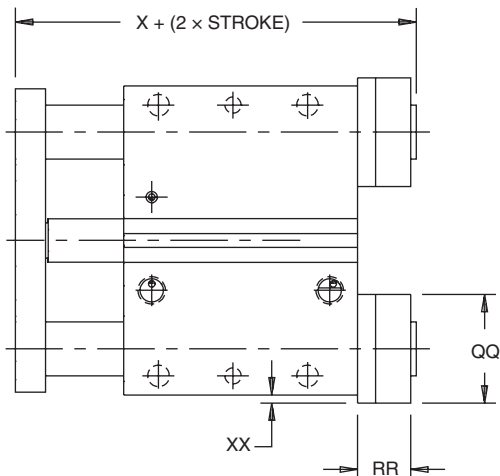

Model	Rod Dia.	X			QQ	RR	XX
		D option	A option	E option			
16	8	57.7 (2.27)	70.7 (2.78)	62.7 (2.47)	18.0 (0.71)	15.7 (0.62)	0
	10	57.7 (2.27)	70.7 (2.78)	62.7 (2.47)	24.0 (0.95)	15.7 (0.62)	1 (0.04)
20	10	54.7 (2.15)	67.9 (2.67)	59.9 (2.36)	24.0 (0.95)	15.7 (0.62)	1 (0.04)
	12	54.7 (2.15)	72.6 (2.86)	64.6 (2.54)	28.0 (1.10)	17.7 (0.70)	3 (0.12)
25	12	58.8 (2.31)	76.5 (3.01)	68.1 (2.68)	28.0 (1.10)	17.7 (0.70)	1 (0.04)
	16	58.8 (2.31)	78.5 (3.09)	70.1 (2.76)	34.0 (1.34)	19.7 (0.78)	4 (0.16)
32	16	62.2 (2.45)	81.9 (3.22)	70.8 (2.79)	34.0 (1.34)	19.7 (0.78)	0
	20	62.2 (2.45)	83.9 (3.30)	72.8 (2.87)	40.0 (1.57)	21.7 (0.85)	3.7 (0.15)
40	16	70.2 (2.76)	89.9 (3.54)	78.8 (3.10)	34.0 (1.34)	19.7 (0.78)	0
	20	70.2 (2.76)	91.9 (3.62)	80.8 (3.18)	41.4 (1.63)	21.7 (0.85)	3.7 (0.15)
50	20	74.3 (2.93)	96.0 (3.78)	83.3 (3.28)	41.4 (1.63)	21.7 (0.85)	0.7 (0.03)
	25	74.3 (2.93)	96.0 (3.78)	83.3 (3.28)	45.0 (1.77)	21.7 (0.85)	5.4 (0.21)
63	20	79.5 (3.13)	101.2 (3.98)	88.5 (3.48)	41.4 (1.63)	21.7 (0.85)	0.7 (0.03)
	25	79.5 (3.13)	101.2 (3.98)	88.5 (3.48)	50.8 (2.00)	21.7 (0.85)	5.4 (0.21)
80	25	96.1 (3.78)	117.8 (4.64)	101.9 (4.01)	50.8 (2.00)	21.7 (0.85)	1.4 (0.06)
	30	96.1 (3.78)	117.8 (4.64)	101.9 (4.01)	54.0 (2.13)	21.7 (0.85)	6.3 (0.25)
100	30	103.3 (4.07)	125.8 (4.95)	109.1 (4.30)	60.5 (2.38)	21.7 (0.85)	3.3 (0.13)
	35	103.3 (4.07)	125.8 (4.95)	109.1 (4.30)	57.0 (2.24)	21.7 (0.85)	5.5 (0.22)

All dimensions in mm (inch)

Contaminant & Weld Flash Covers

A contaminant cover protects the guide rods and bearings from particles and fluid that could cause premature failure.

A weld flash cover protects guide rods and bearings from weld spatter.

Cover option can be ordered on models having the bearings both ends option.

Consult factory to order.

Weld Flash Cover Specifications

Coating Material (exposed side)..... PVC (Black)

Base Material Nomex

Coating Material (other side) PVC (Black)

Material Thickness Range012" - .016" (.3-.4mm)

Temperature Resistance (Nomex)

Briefly..... 642°F (450°C)

Continuously -22° to 572°F (-30° to 300°C)

Temperature Resistance (Coating)

Briefly..... 392°F (200°C)

Continuously -22° to 302°F (-30° to 150°C)

Resistant to..... Chemicals, coolants, solvents, oil

Characteristics..... self-extinguishing, abrasion resistant

Material Weight..... 400 grams/square meter

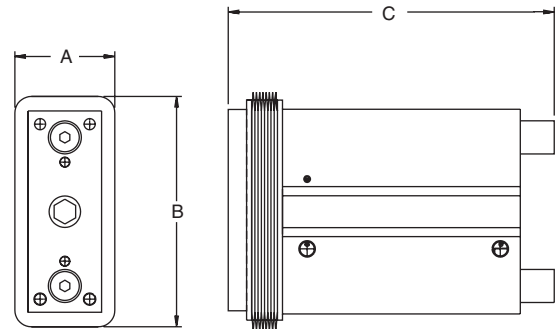

Dimensions

MODEL	A	B	C									
			10	25	40	50	75	100	125	150	175	200
16	42 (1.65)	86 (3.39)	61.2 (2.41)	100.2 (3.94)	135.2 (5.32)	135.2 (5.32)	160.2 (6.31)	200.2 (7.88)	—	—	—	—
20	45 (1.77)	98 (3.86)	—	106.9 (4.21)	141.9 (5.59)	141.9 (5.59)	166.9 (6.57)	216.9 (8.54)	241.9 (9.52)	—	—	—
25	49 (1.93)	112 (4.41)	—	119.9 (4.72)	—	144.9 (5.70)	169.9 (6.69)	194.9 (7.67)	241.9 (9.52)	266.9 (10.51)	—	—
32	62 (2.44)	142 (5.59)	—	127.9 (5.04)	—	152.9 (6.02)	177.9 (7.00)	202.9 (7.99)	266 (10.47)	291 (11.46)	316 (12.44)	341 (13.43)
40	62 (2.44)	152 (5.98)	—	127.9 (5.04)	—	152.9 (6.02)	177.9 (7.00)	202.9 (7.99)	266 (10.47)	291 (11.46)	316 (12.44)	341 (13.43)
50	66 (2.60)	167 (6.57)	—	134 (5.28)	—	159 (6.26)	184 (7.24)	209 (8.23)	274.1 (10.79)	299.1 (11.78)	324.1 (12.76)	349.1 (13.74)
63	77 (3.03)	187 (7.36)	—	134 (5.28)	—	159 (6.26)	184 (7.24)	209 (8.23)	274.1 (10.79)	299.1 (11.78)	324.1 (12.76)	349.1 (13.74)
80	104 (4.09)	244 (9.61)	—	151.8 (5.98)	—	176.8 (6.96)	201.8 (7.94)	226.8 (8.93)	290 (11.42)	315 (12.40)	340 (13.39)	365 (14.37)
100	109 (4.29)	279 (10.98)	—	170.3 (6.70)	—	195.3 (7.69)	220.3 (8.67)	245.3 (9.66)	308.4 (12.14)	333.4 (13.13)	358.4 (14.11)	383.4 (15.09)

All dimensions in mm (inch)



Reed and Solid State Sensors

Sensors are available in both short and standard configurations. Both styles mount in the sensor grooves on the P5T body. The standard sensors mount flush to the body. The short sensor extends out 4.5mm to the cable.

Both styles are available with quick connector or flying leads.

Magnetic piston is standard.

See [Electronic Sensors section](#) for part numbers and specifications.

Drop-in Sensor

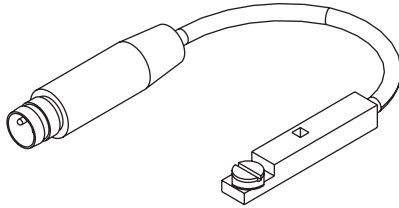

Slide-in Short Sensor

